

## Description

Analogue outputs module is designed for modulation control of electric actuators in air conditioning, heating and cooling automated systems and process industry. It increases the number of analogue outputs of MR 5000 microprocessor controller and can not be used independently.

Analogue outputs module has 4 analogue outputs (AO) (0 – 10 V DC). Module is hardware addressable. It is possible to connect one module to the main microprocessor controller.

LED indicators on the front module plate show the state of each digital input, as well as power supply presence (ON).



## Types

\* 4 outputs 0 – 10 V DC

MAI 1.0

## Technical data

* Power supply:	5V DC from MR 5000 controller
* Bus connection with the controller:	I <sup>2</sup> C
* Analogue outputs:	0 – 10 V DC
* Number of inputs:	4
* Working temperature:	0 – 50°C
* Casing dimensions:	EN50022 (70 x 86 x 57 mm)
* Casing material:	Lexan 940, Noryl VO1550

## Design and installation

Analogue inputs module is installed on DIN 35 mm rail, according to the following diagram:

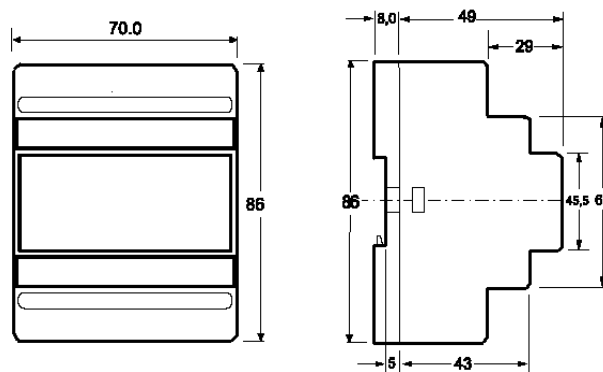

Modules are installed side by side near the microprocessor controller unit. Installation order of the modules can be found in the user manual of the appropriate controller.

## Wiring diagram

Connection of the modules with the microprocessor controller is displayed below. The length of conductor from the controller to the module must not exceed 60 cm. Conductors are placed in a rail box separately from energy conductors.

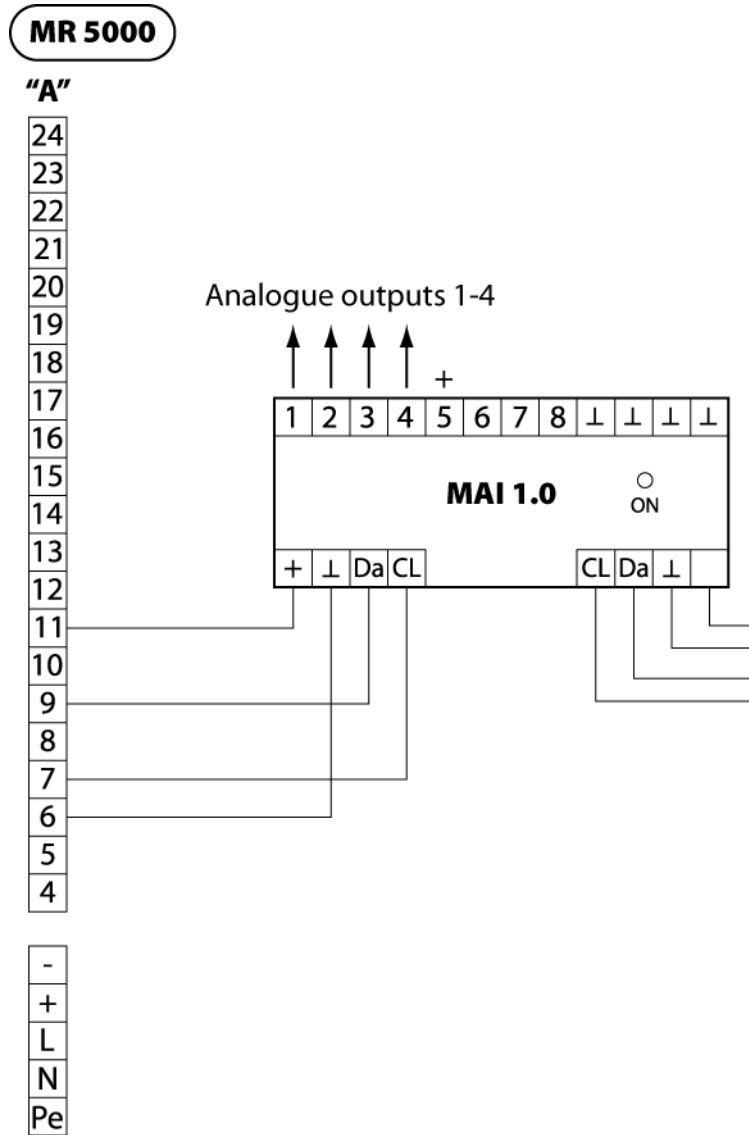

Feniks BB reserves the right to change technical characteristics and/or products without prior notice. All trademarks in this material are property of the respective companies. All rights reserved.

**FENIKS BB**

Čegarska 16  
18000 Niš  
Serbia

Data sheet 09/2007

**Tel. / Fax.**

+381 18 45-75-333

+381 18 45-75-557

**E-mail:**

**info@feniksbb.com**

**Web:**

**www.feniksbb.com**